



INTELLIGENT
YARN PROCESSING



SOLUTIONS



Sample shade card machine

MK 100



www.croon-lucke.com

C+L TEXTILMASCHINEN GmbH, Flachsstrasse 14, D-88512 Mengen / Germany
Tel.: +49 (0)7572 601-0, Fax: +49 (0)7572 601-25 info@croon-lucke.de www.croon-lucke.com

Sample shade card machine **MK 100**



Supply creel (from cone or ball)

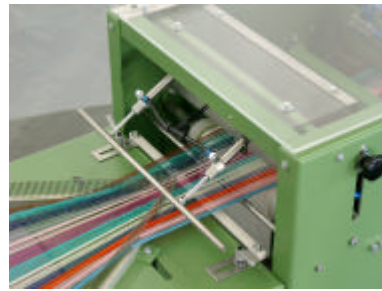

Material inlet



Paper cutting device

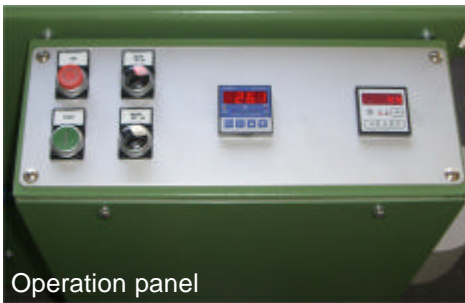

Operation panel

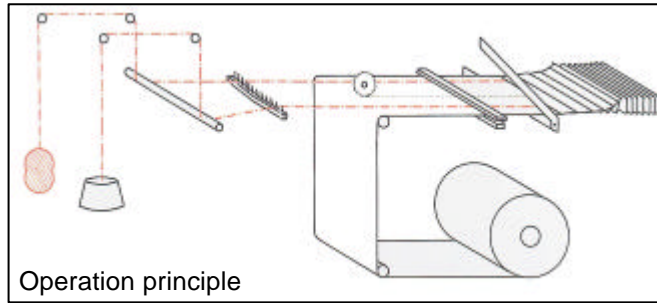

Operation principle

TECHNICAL SPECIFICATIONS:

Sample threads of all different yarns – including fancy yarn – are heat-glued onto a continuous foil paper and cut to required length. The threads can be glued onto the foil on one or both ends. Gluing time is infinitely adjustable for the different yarn counts.

The continuous foil is drawn off a roll with a standard width of 200 mm. The width can be up to max. 300 mm. The supply creel is designed for series of 72 threads, feeding threads from cones on pegs or balls from cups. Creels for additional threads can be supplied.

- foil/paper width: 200 - 300 mm
- paper roll length: 400 m
- sample card width: 25 - 100 mm
- max. output: 2500 cards/h at 100 % efficiency
(output depending on card length)

Standard equipment

- supply creel for 72 threads
- supply from cones on pegs or balls out of cups



www.croon-lucke.com

C+L Textilmaschinen GmbH

Flachsstrasse 14
D-88512 Mengen / Germany
Tel.: +49 (0)7572 601-0
Fax: +49 (0)7572 601-25
info@croon-lucke.de

Dimensional drawing (measurements in mm)

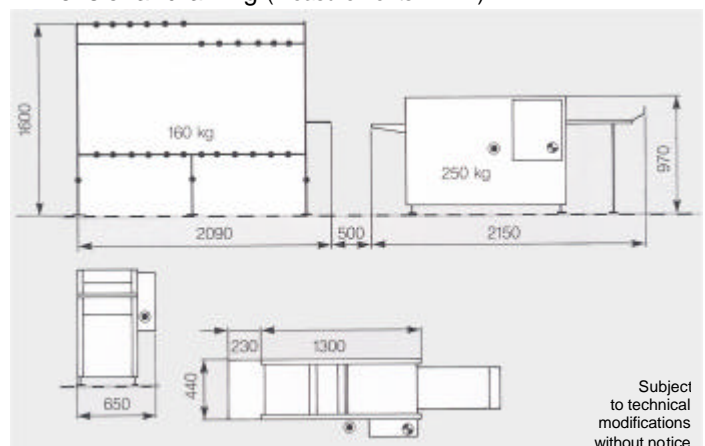

07-07

Subject to technical modifications without notice